



*picture shown with optional casters and bar code scanner

 **WEXXAR BEL®**

BEL 5150E

**SEMI-AUTOMATIC FORM, PACK & SEAL
AUTO ADJUST SYSTEM**

R&E

**ROBOTICS &
END OF LINE**

BEL 5150E

Complete Form, Pack & Seal Solution
Designed For E-Commerce

BEL 5150E VERSATILITY AND FLEXIBILITY

The BEL 5150E is great even for non e-commerce applications and just as a form, pack & seal machine with automatic size change.

User-Friendly And Convenient

Wexar Bel's BEL 5150E revolutionizes e-commerce with the first all-in-one form, pack & seal solution designed to adapt to the fluid and shifting nature of the industry. The ability to automatically change case sizes provides the ultimate flexibility and reliability for a semi-automatic form, pack & seal solution. The BEL 5150E can be integrated with any ERP system or external input device to direct size change, making it adaptable to any application.

When integrated with an ERP system, the full power of the BEL 5150E can be utilized, providing significant optimization and time savings. The ERP is aware of all incoming orders and the optimal case size for each order. This allows the ERP to direct the BEL 5150E to begin changing case size to the next order as the current packaged case exits the machine. When ordered with the case rack, the BEL 5150E directs the operator to pick the correct case blank. Having the optimal case size picked and used offers tremendous savings in shipping costs, dunnage costs and reduced chance of product damage.

ABOUT THE BEL 5150E



IDEAL FOR E-COMMERCE

Integrate with an ERP system for a complete form, pack & seal solution with automated size change



VERSATILITY FOR ANY APPLICATION

Ability to work with any input device including bar code scanner, computer, buttons, switches and more



COMPACT SYSTEM

Compact all-in-one solution fits in almost any application and plant space

COMPLETE SOLUTION

FULLY AUTOMATE YOUR PACKAGING LINE WITH THESE FORMING AND PACKING SOLUTIONS.



PICK-TO-LIGHT CASE RACK

Optional case rack with pick-to-light to advise operator which case size should be used.



NESTAFLEX OUTFEED CONVEYOR

Flexible conveyors which can be manipulated length and shape wise to fit changing and restrictive packaging applications.

CONFIGURATION

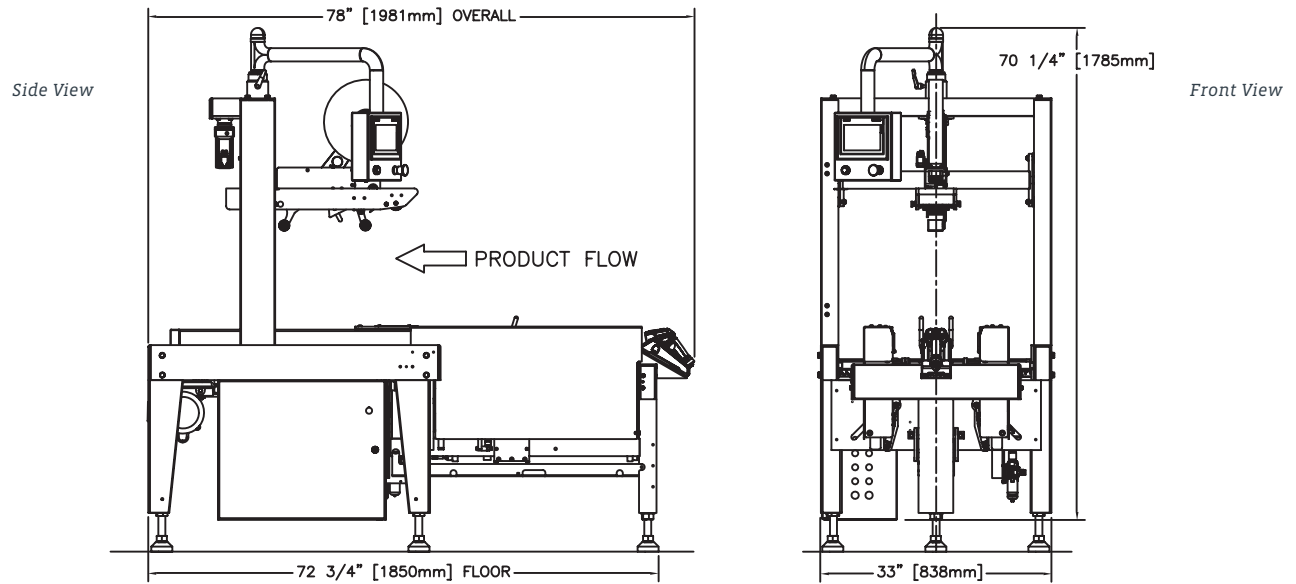

STANDARD FEATURES

- Automatic size change directed through an integrated device, HMI, or ERP system
- Dynamic flap-folding system power folds all bottom flaps
- Positive mechanical case hold-down keeps box in place for hands-free loading
- Uni-Drive squaring technology that provides consistent and uniform seal on cases
- Designed and built in Canada with premium materials
- Reliable, consistent "no break" tape advance with DEKKA SE 22 stainless steel tape heads

OPTIONAL ACCESSORIES

- Pick-to-Light Case Rack
- Locking Casters
- Outfeed table or conveyor
- Bar code scanner or other input device

PRODUCT SPECIFICATIONS

Machine Weight	600 lbs
Machine Dimensions	72.75"(L) x 33"(W) x 70.25"(H)
Air	0.1 cubic feet per cycle at 80-90 p.s.i.
Electrical	120 Volts, 1 PH, 60 Hz - 11 amp draw
Speeds	up to 15 cases per minute

CASE SIZE RANGE

	LENGTH	WIDTH	HEIGHT
Minimum	8" 203 mm	5" 127 mm	4.75" 120 mm
Maximum	24" 610 mm	17.5" 444 mm	25" 635 mm

INFEED/OUTFEED HEIGHT

Minimum	25" (635 mm)
Maximum	32" (813 mm)

Specifications are subject to change without notice.

Note: Casters add 4" to minimum and maximum height



Wexxar Bel is a leading manufacturer of high-performance case and tray formers, sealers and packers, including the IPAK tray former product line that features innovative designs to precisely create hundreds of tray styles. Wexxar Bel continuously pushes the boundaries of development with patented technologies like the Pin & Dome system to exceed the demands of shifting markets, relieving operational bottlenecks in secondary packaging. Wexxar Bel is a product brand of ProMach, a global leader in packaging line solutions. As part of the ProMach Robotics & End of Line business line, Wexxar Bel helps our packaging customers protect their reputation and grow the trust of their consumers. ProMach is performance, and the proof is in every package. Learn more about Wexxar Bel at www.Wexxar.com and more about ProMach at www.ProMachBuilt.com.

13471 Vulcan Way
Richmond, BC, Canada
P: (604) 930-9300
F: (604) 930-9368

E: Wexxar@ProMachBuilt.com
Wexxar.com